

The Flannelboard: Its Construction and Use in English Language Teaching at Primary and Lower Secondary Levels

NOOR AZLINA YUNUS

The purpose of this paper is to show teachers of English that there is at least one piece of classroom equipment

that is both simple and inexpensive to make and, what is more, is fun to use in the second language classroom.

Moreover, imaginative use of the flannelboard is capable of bringing into the often dull, passive environment of the classroom an enormous range of language practice. Pupils enjoy it; teachers enjoy the added response that it inspires in their pupils, and altogether, English Language teaching and learning become much more effective.

First I would like to present the practical aspects of making flannelboards and the accompanying figurines before going on to give examples of the use of the flannelboard in teaching English as a second language.

What is a flannelboard?

Basically, a flannelboard is a piece of softboard (or any other suitable support material) which is covered with a piece of cloth which has adhesive qualities, such as flannel or felt. The basic principle on which the flannelboard works is that a cloth with a rough surface will cling to another surface without any adhesive if they are lightly pressed together. Thus, to the basic flannel surface we can attach figurines (or cut-outs) merely by lightly pressing them on to the surface. All a teacher needs then for an interesting lesson is the background cloth (on a backing board) and teaching items (figurines or flashcards).

The greatest advantage of a flannelboard is that it is a dynamic medium. Its usefulness as a teaching device lies in the fact that it provides a way of presenting 'mobile' situations. Change can be shown by adding or taking away or transferring figurines and flashcards. Moreover, the flannelboard is easy to store and light to carry. A teacher by herself, or in collaboration with colleagues, can build up a store of flannelboard items which can be

used to teach almost any structure in the syllabus or any of the language skills.

How to make a flannelboard and figurines.

1. **Background material:** This can be of thin felt, flannel, suede or any other locally available material which has a fluffy surface.

2. **Mounting the background material:** The background material can be mounted on various surfaces: (a) a piece of softboard; (b) a piece of plywood; (c) stiff cardboard; or (d) thrown over an easel board.

From my experience it is best to mount a piece of flannel (the type used here for children's pyjamas) on to a piece of softboard, 2' x 2'8". As softboard is sold only in 4' x 8' pieces, it is best to cooperate with colleagues to share one 4' x 8' piece. Ask the hardware shop where you purchase the softboard to cut it for you into 6 small pieces, 2' x 2'8".

You will need one yard of flannel. Although some teachers favour a dark colour (to represent a blackboard) I personally prefer a pale green or light blue which can readily simulate grass or water. White is to be avoided as it soils too easily. Bright colours (especially red and orange) are not suitable as the figurines tend to be obscured by a bright background.

The flannel can be spread over the surface of the softboard and pinned or stapled around the edges or behind, (Figure 1). Alternatively, the flannel can be gummed to the backing board. Care must be taken when doing this as the gum tends to saturate the cloth. The advantage in using staples or thumbtacks is that the material can be removed for washing, or can be simply reversed when soiled.

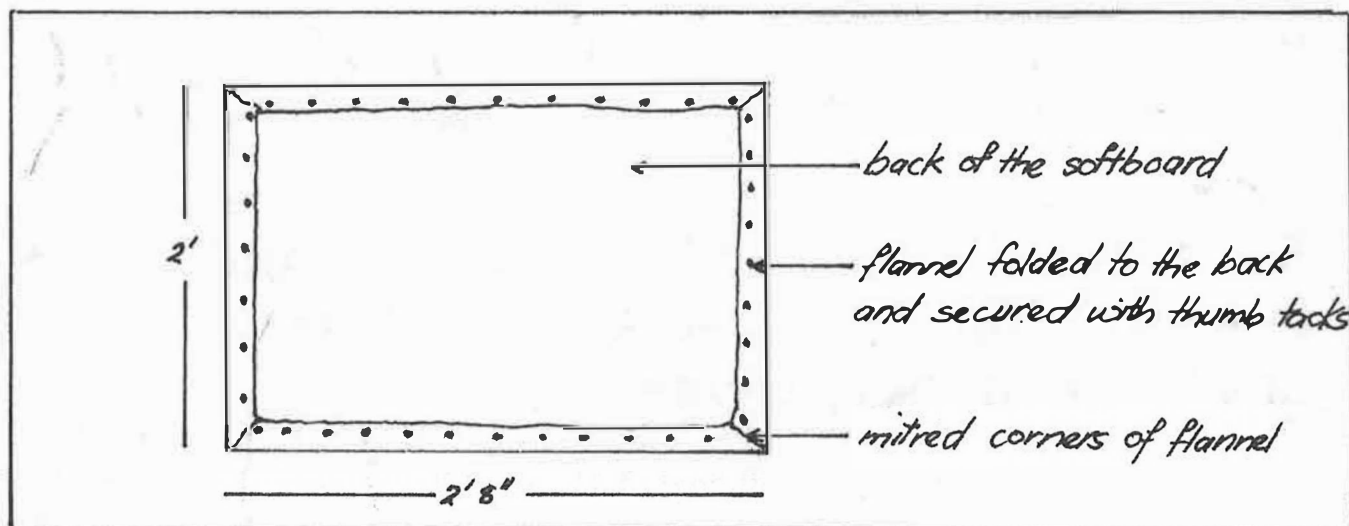

Figure 1.

3. **Making the figurines or cut-outs:** These can comprise a multitude of media:—

(a) Teacher-made drawings (of people, objects, etc.). Reasonably thick cardboard should be used for these to ensure durability. The figures should be drawn boldly and without too much detail. It is important to remember that the figurines should be large enough to be seen by pupils at the back of the class.

(b) Flashcards, captions, sentences. These should be written on cardboard, preferably white. The lettering should be bold to ensure legibility by all pupils. Printed small lettering rather than capital lettering is best.

(c) Pictures from magazines. These should be mounted on manila card and then cut out. It is not necessary to cut around the exact outline of an object; cutting around it boldly is adequate. Also, when searching for magazine pictures, do not bother too much if the objects are not in realistic proportion. All the objects will need to be large if they are to be visible.

(d) Figurines cut from felt, woollen material, velvet, suede, blotting paper, sponge, balsa wood or any other material with good adhesive qualities. These are easy to prepare and add variety to the more conventional figurine.

Although figurines cut out of felt, woollen material and similar types of cloth will adhere to the flannelboard by themselves, those made from cardboard (including magazine pictures mounted on card), will need some adhesive material attached to the back to make them stick on to the board. A small piece of sandpaper or felt, gummed or attached with double-sided cello tape, will provide excellent adhesion (Figure 2). One minor disadvantage of the flannelboard is that when there is a draught figurines may not adhere too well. Thus, it is necessary to make sure that there are 2–3 small pieces of sandpaper on the back of each figurine.

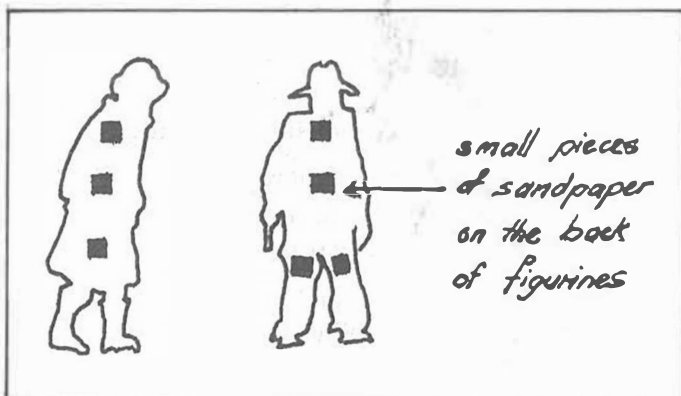

Figure 2.

4. **Suggested figurines or cutouts:** Here is a list of items that would be useful in language teaching:—

- (a) People (adults and children) performing actions:
 - walking, running, talking, carrying something, reading, studying, cleaning, watching (television), etc.
- (b) Professions:
 - teacher, doctor, nurse, postman, farmer, soldier, gardener, servant, fisherman, labourer, shopkeeper, etc.
- (c) Vehicles:
 - car, bus, aeroplane, bicycle, scooter, trishaw, train, etc.
- (d) Street Objects:
 - shop windows, lamp post, letterbox, road signs, buildings (e.g. Post office, hospital), etc.
- (e) Objects seen in a general outdoor scene:
 - animals (dogs, cats), flowers, trees, houses, etc.
- (f) Interior Objects:
 - chair, table, lamp, radio, television, items of clothing, bed, crockery, books, etc.

5. **The flannelboard stand:** Because the flannelboard needs to be tilted on an angle to prevent the figurines from falling off, it is not possible to hang it in the front of a classroom on or near the blackboard. It needs to be placed on the teacher's table on a stand. It is recommended that teachers get a carpenter to make them a stand as shown in figure 3.

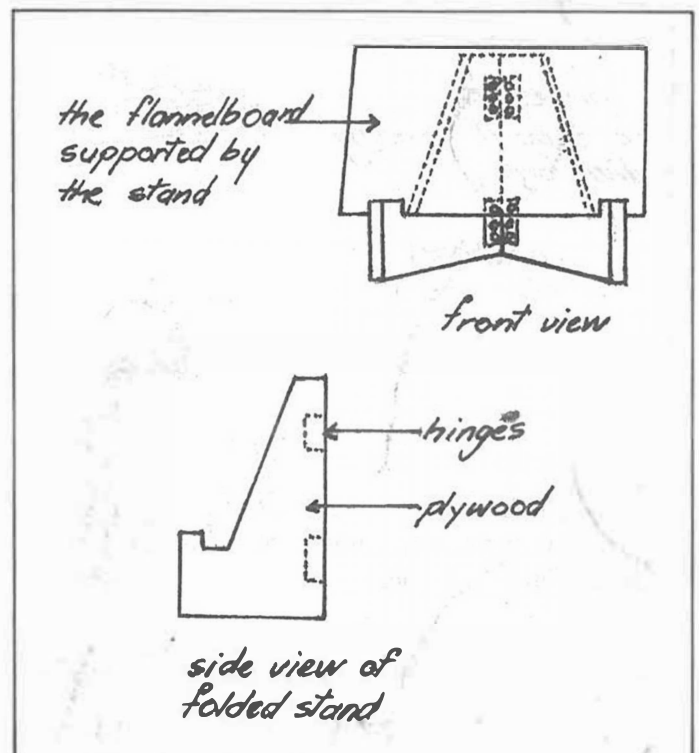

Figure 3.

Note that this stand can also be used to support other teaching material, for instance, composite pictures, provided that a piece of stiff cardboard is placed at the back of the picture to give support.

6. **Storage of figurines:** There are various ways of storing cutouts and below I give three suggestions:—

(a) You may like to group all the items you have prepared for a particular item or structure in the syllabus. The sets can then be put in envelopes with the appropriate syllabus item written on the outside. However, this method can be wasteful as most figurines have multiple purposes. If you are a prolific artist though and you do not wish to go to the trouble of sorting out which figurines you need for a particular lesson, this method is suitable.

(b) It is probably better to group your figurines in sets — of people, professions, household objects, animals, etc. Store each set in clear plastic envelope so that you can see at a glance what the contents can be used for. Also write a list of the contents of each envelope (and their possible use?) and attach it to the envelope.

(c) Another method of storing sets or categories of figurines is to adapt a small cardboard box (something like a shoe box), (Figure 4). In both ends make a row of holes about one inch apart. Thread a piece of string lengthwise, back and forth, using alternate holes. These will become compartments by slipping a piece of

scope for using the flannelboard both to introduce and to practise new language items, how the teacher uses it will depend to a certain extent on the language proficiency of the class and also on the level of sophistication of the pupils. For instance, cartoon-like figurines may appeal more to a certain age group than the more realistic magazine cutouts. Even in the best of Form III classes, however, there is room for the flannelboard as a motivating device as well as for the presentation and consolidation of structures.

Example 1: For vocabulary building and spelling.

1. The teacher (or why not the pupils themselves?) can prepare letters of the alphabet from felt, flannel or cardboard.
2. These are distributed among the pupils.
3. On a (group) competitive basis, pupils can build up a word which the teacher has called out; or build up sentences, change word order, etc.

Example 2: Identification of various parts of speech.

- (a) Nouns: This is an obvious use but still effective. (“What is this?”), (“That’s a”);
- (b) Prepositions and prepositional phrases: (showing place, position, direction and motion):
 1. The teacher can draw a fruit (e.g. a pineapple) and an insect (a worm or an ant) along with appropriate preposition flashcards.

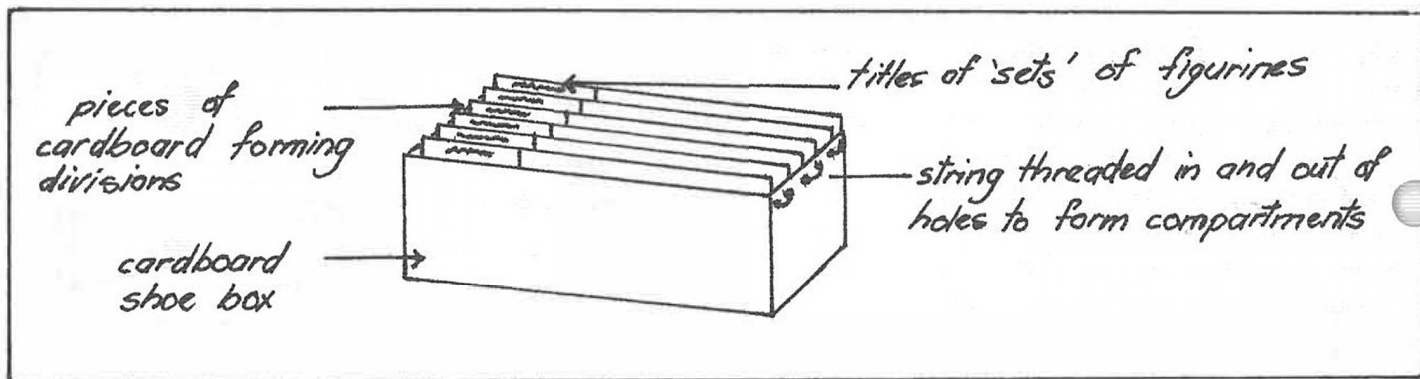

Figure 4.

cardboard in between the strings. At the top of each piece of cardboard you can write the name of the set plus teaching suggestions.

Uses of the flannelboard in English language teaching.

Let us now look at some of the ways in which the flannelboard can be used in primary and lower secondary English classrooms. Although there is a great deal of

2. The teacher could say something like this:

“This is a pineapple and this is a worm”.

“We will call the worm Lowly ...”

“Where is Lowly Worm now?”

near
above

“He is the pineapple.”

below
through

Figure 5.

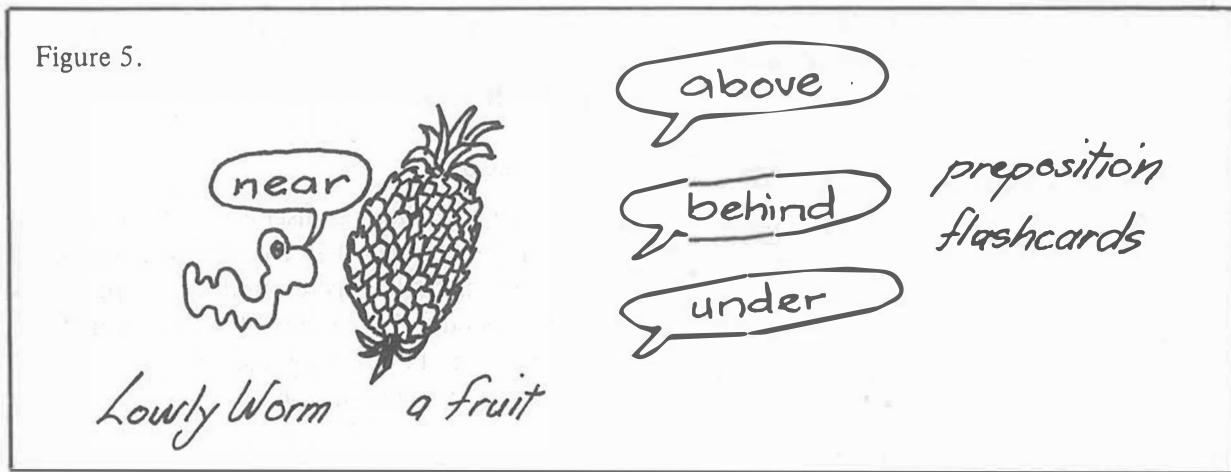

Similarly, prepositional phrases can be taught using figurines and flashcards like these:

Figure 6.

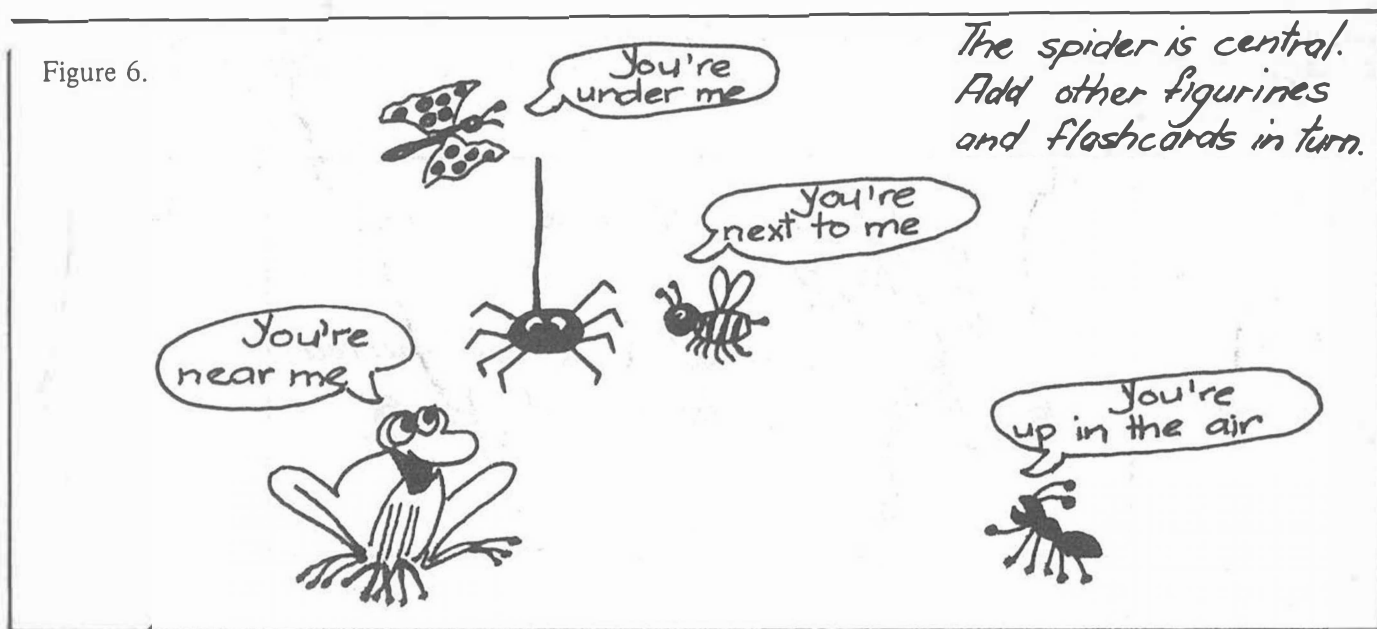
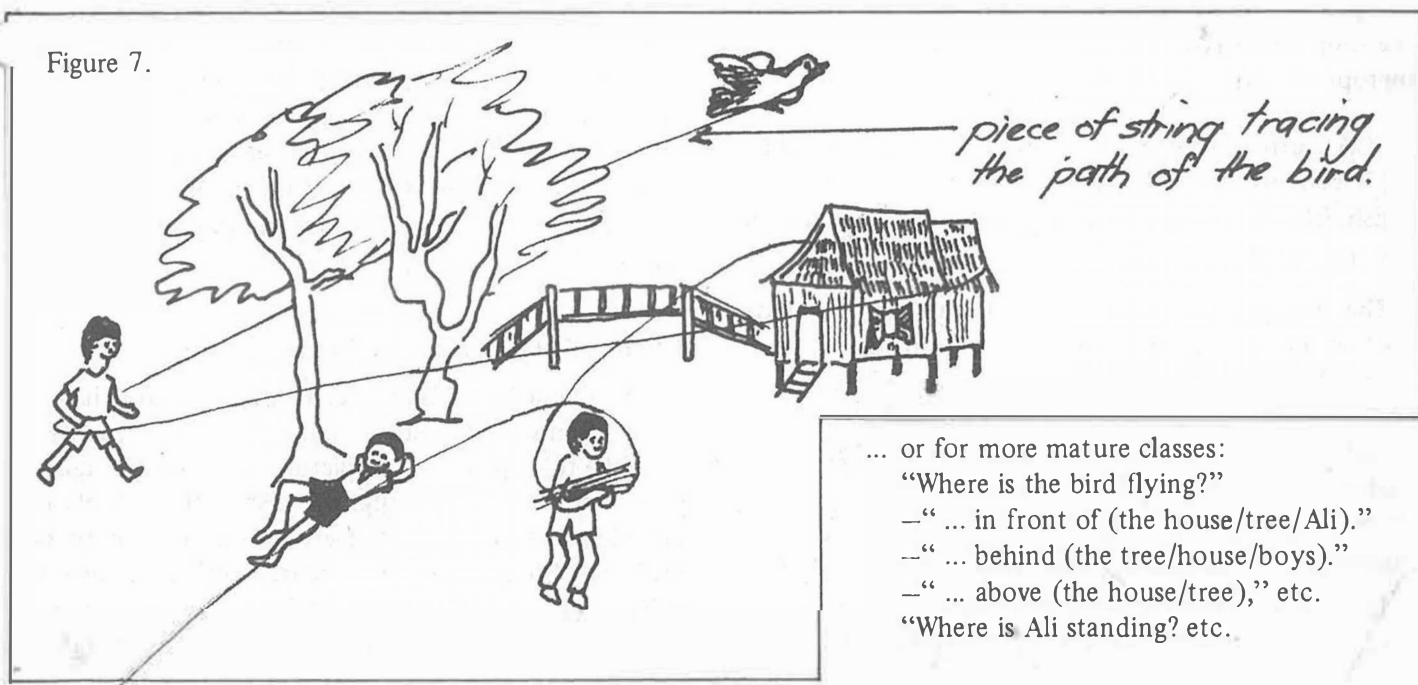

Figure 7.



(c) Adjectives and comparatives and superlatives.

Here different sizes and shapes of people and objects can be lined up and compared.

Note that although concrete nouns and some adjectives and prepositions can be easily taught using the flannelboard, words that are abstract or subtle are usually quite impossible to represent or suggest.

Example 3: Teaching various tense forms:

Because the figurines are easily moved around they can be used to teach a wide range of tense forms. A particularly useful way of teaching the present continuous is to make jointed figures (Figure 8), whose legs and arms can assume a range of postures to suit various contexts. This is infinitely more effective than trying to teach continuous tenses using either a static wall chart or flashcards.

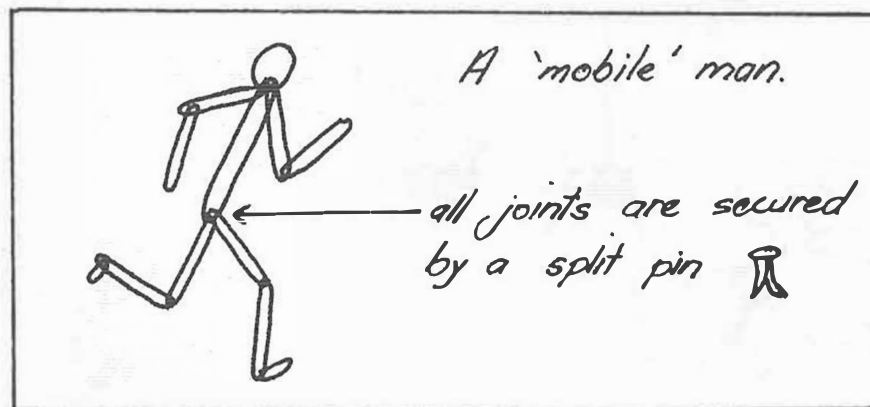

Figure 8.

The simple past tense can be developed (with appropriate cutouts) along these lines:

"Cik Normah *went* to the market to buy some food. First she *went* to the fishmonger and *bought* some fish. Then she *went* to the vegetable seller and *bought* some carrots and beans. Then she *went* home."

The enterprising teacher can work out many contexts or situations where tenses can be taught through question and answer, statement and response, etc. in conjunction with flannelboard cutouts and flashcards. A cardboard clock (with moveable hands) can help teach the concept of time and tense.

Example 4: Sentence substitution and transformation:

Flashcards used on the flannelboard are useful to teach sentence patterns as the pupils can come forward

and manipulate the cards. The teacher can also show subject, predicate and qualifiers by printing these on different coloured cardboard.

Example 5:

After a teacher has discussed letter writing formats with pupils she can then check their understanding by distributing flashcards to pupils containing parts of the address, body of the letter, close, plus appropriate punctuation. Pupils can come up in turn and compile the letter on the flannelboard.

Example 6: Dialogues:

Cutouts can be used as a cue for the reproduction of short dialogues. Many features of spoken English can be practised ranging from agreement to disagreement to contradiction, etc. The teacher should first give the

pupils a model dialogue along with appropriate figurines so that they understand what is required of them. She can then introduce variations by using different combinations of cutouts. At first the teacher may like to merely change the cutouts of the people who are talking and then go on to change the subject they are talking about.

Example 7: Guided composition.

The flannelboard is an excellent medium for the oral preparation stage of guided composition. The teacher may like to display a single picture or a series of figurines before encouraging the pupils to discuss the cutouts as a prelude to writing. Alternatively, the teacher can prepare the pupils for a composition exercise by telling them a story using appropriate cutouts. For example, you may set a topic such as 'A trip to the zoo'. The teacher could

first of all show the pupils individual cutouts of various animals (and elicit the names from the pupils). She could then describe, using cutouts, how 'Ali' spent a day at the zoo; how he got there, what he saw; who he went with, etc.

Example 8: Elucidation of reading comprehension passages.

Far too often in set English texts the comprehension passages are too difficult both language-wise and theme-wise. These reading passages can be elucidated in the following way:—

1. The teacher narrates the story of the passage. At the same time she pastes the appropriate cutouts on the flannelboard.

2. The teacher re-tells the story but this time a pupil is asked to place the cutouts.
3. A pupil can then come to the front of the class and narrate the story once more while another pupil pastes on the cutouts.

By this time the pupils should be able to tackle the reading passage with some confidence. The content and vocabulary and structures will be more meaningful as pupils mentally visualise the teacher's (and fellow pupils') dramatization of the story.

The above are just a few simple examples of what can be done with the flannelboard. A resourceful teacher will think of many other ways in which to introduce, practise and test items using the flannelboard. In what ever way the teacher uses it, the effectiveness of her teaching and the enjoyment of the pupils will be enhanced.